

GBA



New insert grades provide smooth chip control and excellent surface finish

New insert grades PR20 series
provide longer tool life

PR2015 : for steel and cast iron

PR2025 : for steel and stainless steel

Excellent chip control with GM chipbreaker



PR20 series

For steel, stainless steel and cast iron



**KEEPS YOU
AHEAD**



External and internal shallow grooving tools

GBA

New generation insert grades for Steel,
Stainless steel and Cast iron
Excellent chip control and superior surface finish



1 New grades PR20 series for general purpose
MEGACOAT NANO EX coating technology provides long tool life

New grades for grooving and cut-off solutions



PR20 series

The newly developed "MEGACOAT NANO EX" is a PVD coating specialized for Grooving and Cut-off machining

Multi-layering of high content aluminum nano layers

Stable high-temperature hardness with excellent wear and oxidation resistance



PR2015

1st recommendation for steel and cast iron
Excellent balance of hardness, toughness and versatility

PR2025

Stability oriented for steel
1st recommendation for stainless steel
Excellent fracture resistance and high stability for interrupted machining

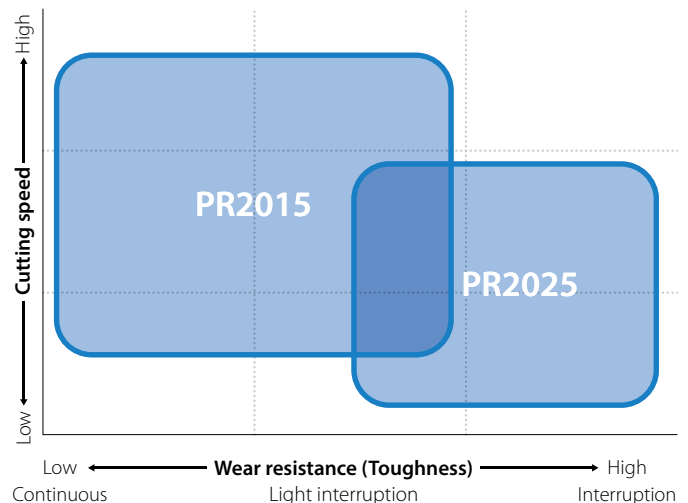

Workpiece	P Steel					M Stainless steel					K Cast iron				
	01	10	20	30	40	01	10	20	30	40	01	10	20	30	40
ISO															
Lineup	General purpose/1st recommendation PR2015					1st recommendation PR2025					1st recommendation PR2015				
	Stability oriented PR2025														

Excellent wear and fracture resistance for long tool life and good surface finish

Delivers superior wear resistance and fracture resistance

Good surface finish

Wear resistance comparison (Internal evaluation)

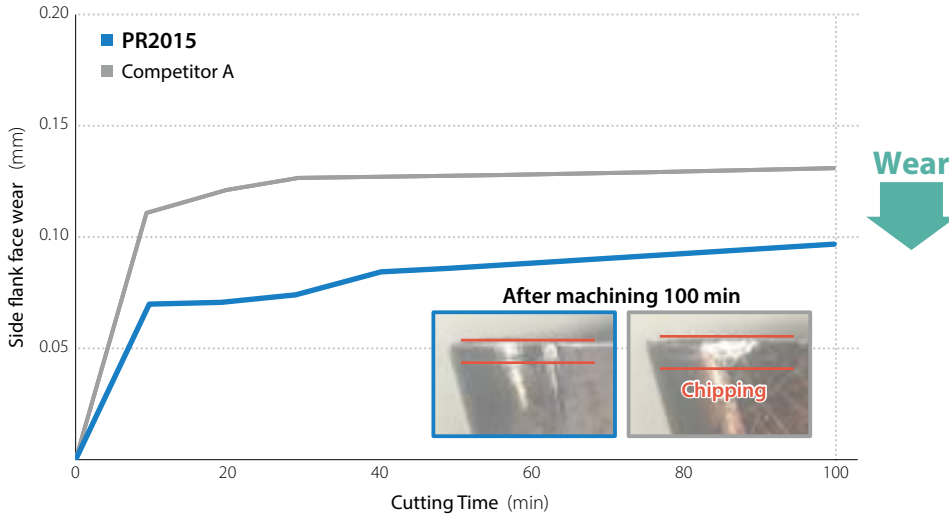

Cutting conditions : $V_c = 200$ m/min, $a_e = 1.5$ mm (shouldering), $f = 0.1$ mm/rev, GBA43R300-030GM, Workpiece : S45C

Surface finish comparison (Internal evaluation)

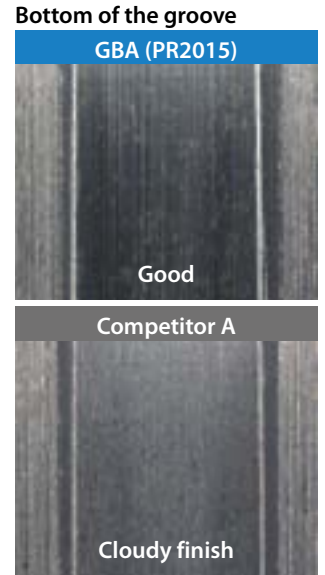

Cutting conditions : $V_c = 200$ m/min, $a_e = 1.5$ mm (grooving), $f = 0.1$ mm/rev, GBA43R300-030GM, Workpiece : SCM420

Excellent fracture resistance and high stability for interrupted machining

Fracture resistance comparison (Internal evaluation)

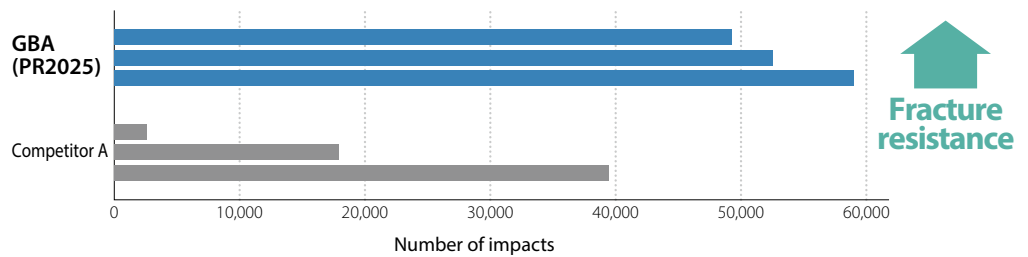

Cutting conditions : $V_c = 150$ m/min, $a_e = 1.5$ mm (shouldering), $f = 0.15$ mm/rev, GBA43R300-030GM, Workpiece : SCM440 (4 Grooves in Workpiece)

Long tool life for stainless steel and cast iron

SUS304 Wear resistance comparison (Internal evaluation)

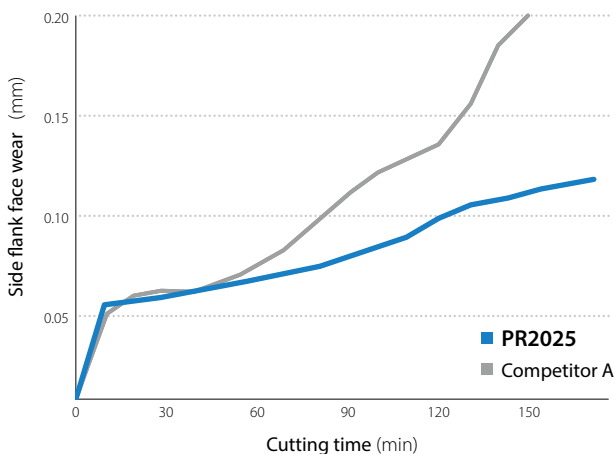

Cutting conditions : $V_c = 150$ m/min, $a_e = 1.5$ mm (shouldering), $f = 0.1$ mm/rev, GBA43R300-030GM

FCD450 Wear resistance comparison (Internal evaluation)

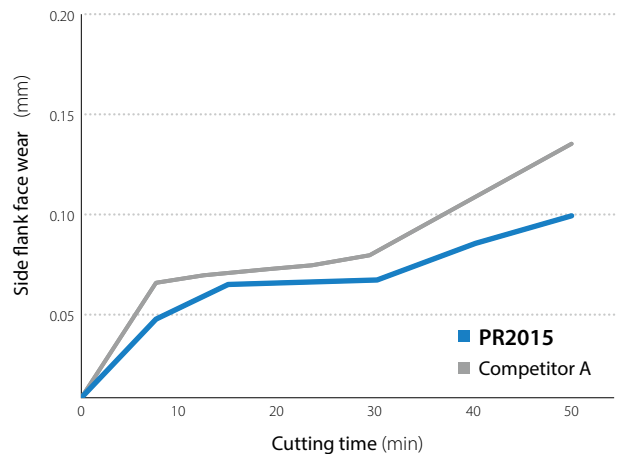

Cutting conditions : $V_c = 200$ m/min, $a_e = 1.5$ mm (shouldering), $f = 0.1$ mm/rev, GBA43R300-030GM

2

New coating MEGACOAT NANO EX for grooving and cut-off machining Long tool life and high stability with excellent high-temperature hardness

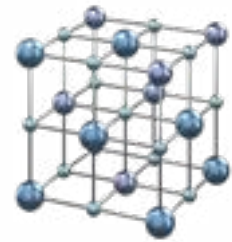

Achieve long tool life and high stability with the combination of

High content aluminum nano coating layer

-New coating for grooving launched-

Challenges

Since most of the grooving is continuous machining, the wear progress of the insert is rapid. Tool life is shortened due to deterioration of surface finish, machining accuracy, burr, etc.

SOLUTION

MEGACOAT NANO EX is a special nano coating layer with a high aluminum content developed by Kyocera's unique technology. Solve the machining challenges with excellent wear resistance, high-temperature hardness and plastic deformation resistance.

Coating characteristics (Internal evaluation)

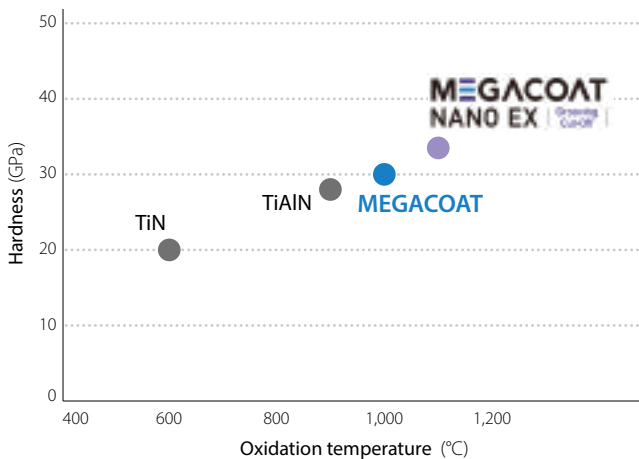

Comparison of vickers hardness transition with temperature (Internal evaluation)

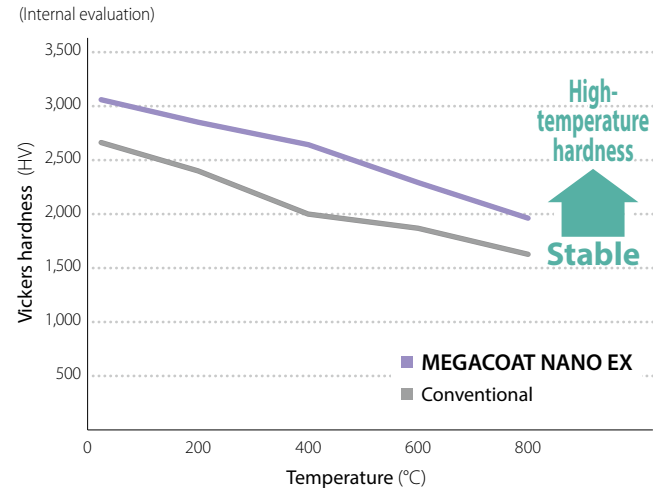

Special nano coating layer

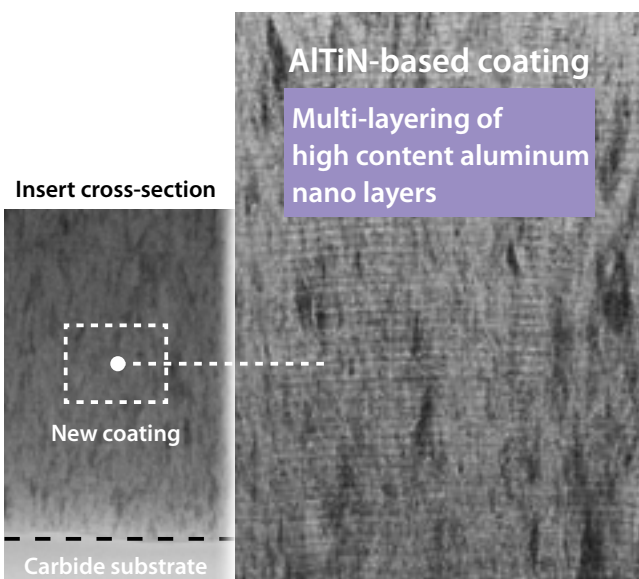

Long tool life Exellent wear and fracture resistance

Multi-layering of high content aluminum nano layers added with high melting point material having different concentration

Suppresses hexagonal crystal precipitation and achieves excellent oxidation resistance

Patent applied
Unique Technology

Stable machining High coating toughness

Crystal grain refinement

Optimized internal stress suppresses crack growth

Unique technology

Proprietary coating process Improve high aluminum-containing nano layers performance

Established a proprietary coating process with the addition of high melting point materials

Patent applied

Maintains a cubic crystal structure to maximize the properties of aluminum (Al)

Correlation between aluminum content and coating hardness (Internal research)

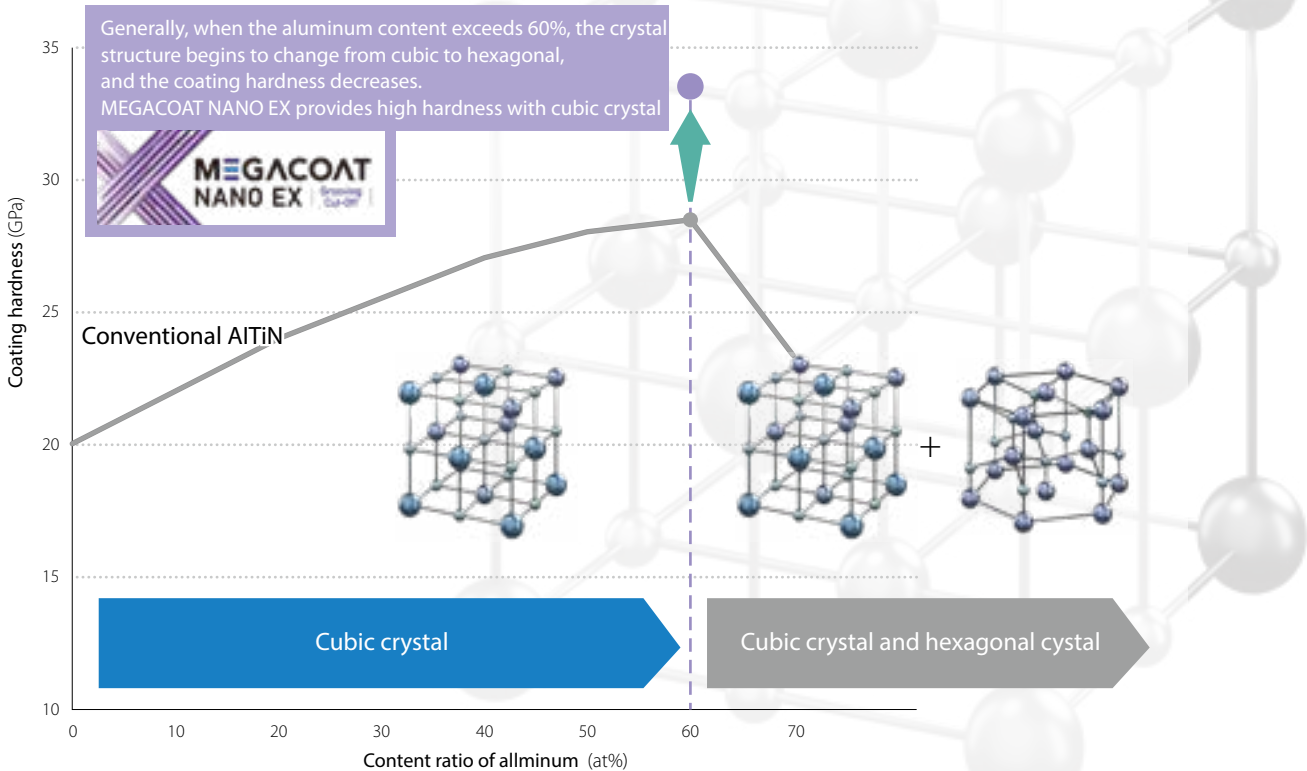

Oxidation progression comparison (Internal evaluation)

Suppresses oxidation progression with excellent oxidation resistance

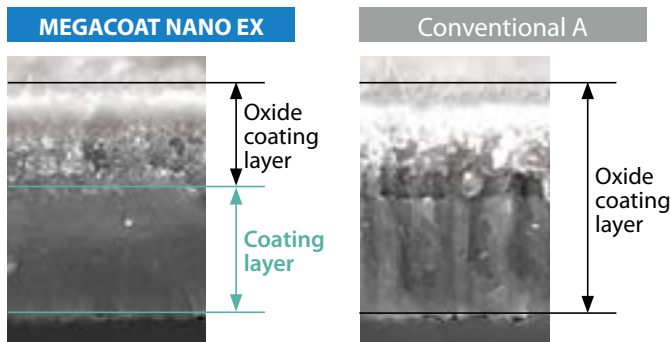

*Section after holding at 1,100 degrees for 5 minutes in air

Coating layer toughness evaluation (Internal evaluation)

Excellent coating toughness with small crack length

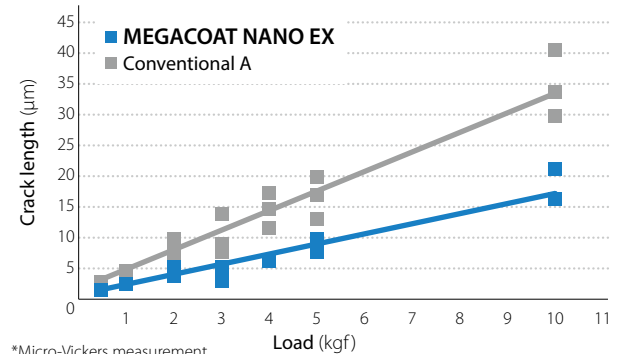
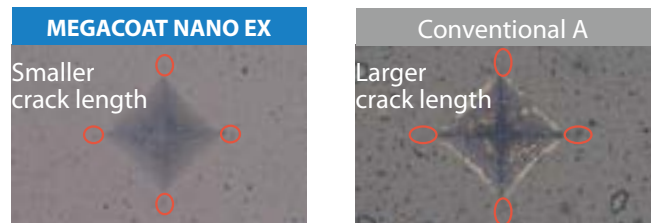

3 Smooth chip control with GM chipbreaker

Multi-bump design

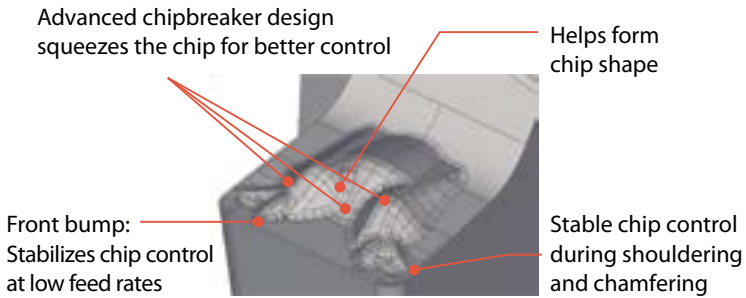

Chip control comparison (Internal evaluation)

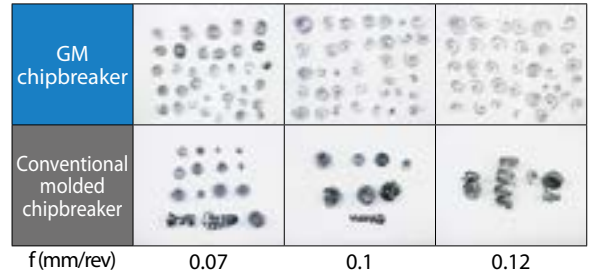

Cutting conditions : Vc = 200 m/min, Edge width 2.0 mm, Grooving Workpiece : SCr420 (ø40)

4 Great for high pressure coolant Provides excellent chip control and long tool life

Great for high pressure coolant, toolholder for shallow grooving

KGBA-JCT

KGBA-JCT can direct coolant closer to the cutting edge from the top of the insert
Excellent chip control and longer tool life

Coolant hole

Coolant is discharged to the cutting edge
Prevents coolant stream spreading and slowing coolant flow

Coolant direction

Sufficient coolant between the chipbreaker and the chips
Stable chip curls and sufficient cooling of the insert

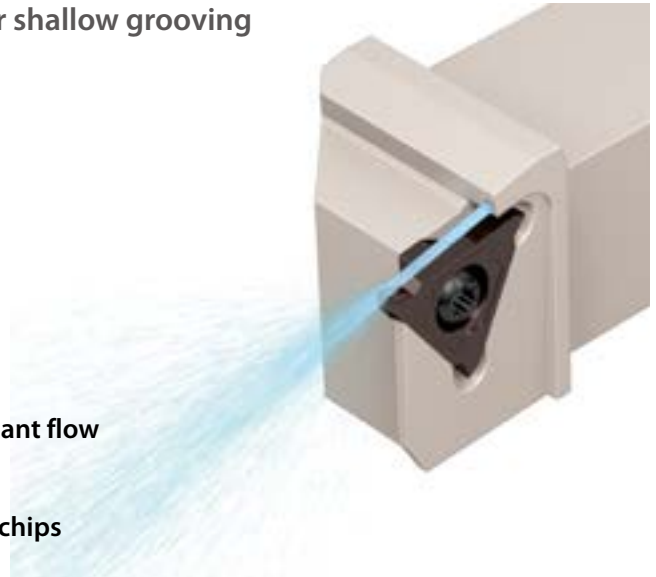

Chip control comparison (Internal evaluation)

Alloy steel (SCr420)

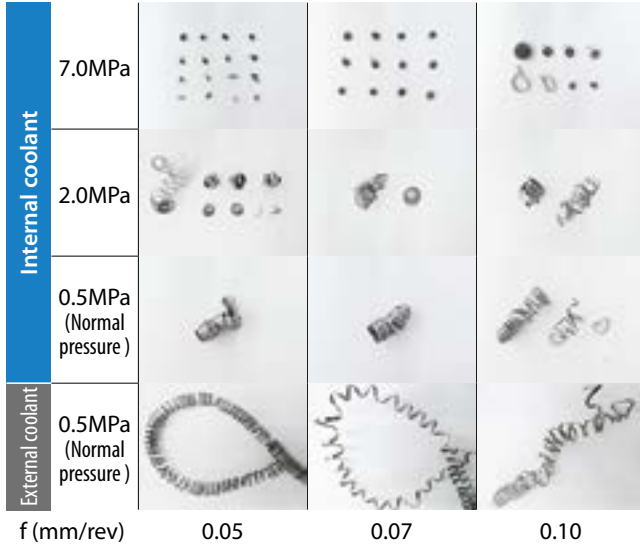

Stainless steel (SUS304)

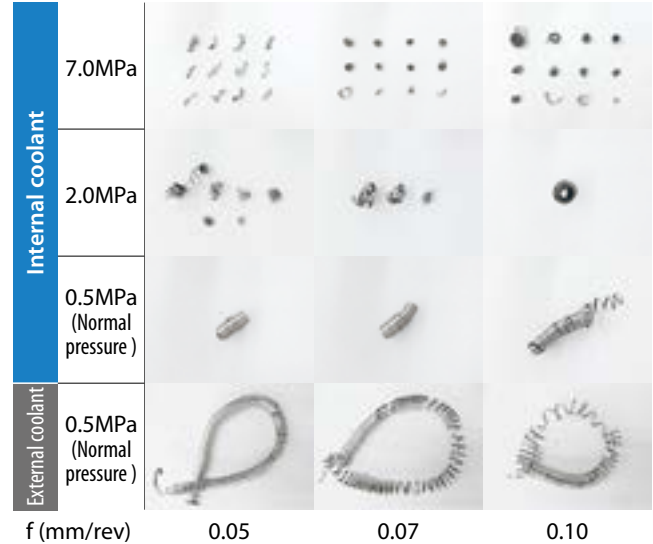

Cutting conditions : Vc = 150 m/min (Alloy steel) / 100 m/min (Stainless steel), f = 0.05~0.1 mm/rev, Groove depth = 2 mm, Wet
KGBAR2525K22-15JCT, GBA43R200-020 (PR1215)

Applicable inserts

Ground chipbreaker

NEW NEW

Description	Dimension (mm)			MEGACOAT NANO EX		MEGACOAT	MEGACOAT NANO	MEGACOAT Cermet	Cermet		Carbide	Applicable toolholders
	CW Edge width (W)	CDX Available grooving	RE Corner-R	PR2015	PR2025	PR1215	PR1625	PV7040	TC40N	TN90	KW10	
				PR2015	PR2025	PR1215	PR1625	PV7040	TC40N	TN90	KW10	
GBA32 ^{R/L}	033-005 ^{*1}	0.33	0.8	●	●	○	○	●				1
	050-005 ^{*2}	0.50	1.0	●	●	○	○			R	●	
	050-005		1.2	●	●	○	○					
	075-005	0.75		●	●	○	○	●		R	●	
	095-005	0.95		●	●	○	○			R	●	
	100-005	1.00		●	●	○	○	●			●	
	110-005	1.10		●	●	○	○					
	120-005	1.20		●	●	○	○					
	125-020	1.25		●	●	○	○	●			●	
	130-020	1.30		●	●	○	○					
	140-020	1.40	2.5	●	●	○	○					
			2.0							R	●	
	145-020	1.45	2.5	●	●	○	○					
			2.0							R	●	
	150-020	1.50	2.0					●			●	
			2.5	●	●	○	○					
	160-020	1.60		●	●	○	○					
	170-020	1.70		●	●	○	○					
	175-020	1.75	2.0								●	
	200-020	2.00		●	●	○	○	●			●	
	225-020	2.25	2.5	●	●	○	○					
	250-020	2.50		●	●	○	○				●	
	300-020	3.00		●	●	○	○					
GBA43 ^{R/L}	125-010	1.25	2.0	●	●	○	○					2
	125-020		3.5	●	●	○	○	●			●	
	140-020	1.40	2.0	●	●	○	○					
	145-020	1.45		●	●	○	○					
			0.1	●	●	○	○					
			0.2	●	●	○	○					
	150-010	1.50		●	●	○	○					
	150-020		3.5	●	●	○	○	●			●	
	170-020	1.70		●	●	○	○					
	175-020	1.75		●	●	○	○			R	●	
	185-020	1.85		●	●	○	○			R	●	
	195-020	1.95		●	●	○	○					
	200-010		0.1	●	●	○	○					
	200-020	2.00		●	●	○	○	●			●	
	225-020	2.25	0.2	●	●	○	○					
	230-020	2.30		●	●	○	○				●	
	250-010		5.0	●	●	○	○					
	250-030	2.50	4.0					●			●	
			5.0	●	●	○	○					
	265-030	2.65	4.0						R		●	
			5.0	●	●	○	○					
	280-030	2.80	4.0						R		●	
			5.0	●	●	○	○					
	300-010		0.1	●	●	○	○					
	300-030	3.00	4.0					●			●	
			5.0	●	●	○	○					
	325-030	3.25	0.3	R	R		R					
			4.0									
	330-030	3.30		●	●	○	○					
			0.1	●	●	○	○					
	350-010		0.1	●	●	○	○					
	350-030	3.50	0.3	●	●	○	○					
	400-010		0.1	●	●	○	○					
	400-040	4.00		●	●	○	○	●		R	●	
	430-040	4.30		●	●	○	○			R	●	
	450-040	4.50	0.4	●	●	○	○			R	●	
	480-040	4.80		●	●	○	○			R	●	

Edge width tolerance : ±0.025 (*1 and *2 are as follows) ● : Available R : R-hand only in stock
 *1. Edge width tolerance for GBA32^{R/L} 033-005 : 0.33^{±0.025} *2. Edge width tolerance for GBA32^{R/L} 050-005 : 0.50^{±0.025}

Classification of usage

● : Light Interruption /1st Choice ● : Continuous /1st Choice
 ○ : Light Interruption /2nd Choice ○ : Continuous /2nd Choice

Description	Dimension (mm)			Cermet	Applicable toolholders
	CW Edge width (W)	CDX Available grooving depth	RE Corner-R		
GBA32 ^{R/L}	050-005F ^{*1}	0.50	1.0	●	1
	075-005F	0.75		●	
	095-005F	0.95	0.05	●	
	100-005F	1.00		●	
	125-020F	1.25	2.0	●	
	145-020F	1.45		●	
	150-020F	1.50	0.2	●	
	175-020F	1.75		●	
	200-020F	2.00	2.5	●	
	250-020F	2.50		●	
GBA43 ^{R/L}	125-020F	1.25	2.0	●	2
	145-020F	1.45		●	
	150-020F	1.50	0.2	●	
	175-020F	1.75		●	
	185-020F	1.85	3.5	●	
	200-020F	2.00		●	
	230-020F	2.30		●	
	250-030F	2.50	4.0	●	
	265-030F	2.65		●	
	280-030F	2.80	0.3	●	
	300-030F	3.00		●	
	330-030F	3.30		●	
	350-030F	3.50		●	
	400-040F	4.00	5.0	●	
	430-040F	4.30	0.4	R	
	450-040F	4.50		R	
	480-040F	4.80		R	

Edge width tolerance : ±0.025 (*1 is as follows)
 *1. Edge width tolerance for GBA32^{R/L} 050-005F : 0.50^{±0.025}
 ● : Available R : R-hand only in stock

Insert design

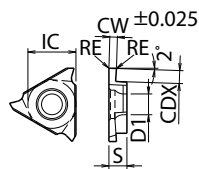
Shape (Right-hand)	Type	IC	S	D1
Ground chipbreaker (Sharp cutting edge)	GBA32...	9.525	3.18	4.4
	GBA43...	12.70	4.76	5.5
	GBA43 ^{R/L} 480	12.70	5.00	5.5

CDX shows available grooving depth.

Applicable toolholder description

- 1 : KGBA^{R/L}...16 (JCT), KGBAS^{L/R}...16
KIGBA^{L/R}...16 (Internal)
- 2 : KGBA^{R/L}...22-15 (JCT), KGBAS^{L/R}...22-15
KIGBA^{L/R}...22 (Internal)
- 3 : KGBA^{R/L}...22-25T5/ 22-25JCT
KGBAS^{L/R}...22-25T5, KIGBA^{L/R}...22 (Internal)
- 4 : KGBA^{R/L}...22-25(T5)/ 22-25JCT
KGBAS^{L/R}...22-25(T5), KIGBA^{L/R}...22 (Internal)
- 5 : KGBA^{R/L}...22-35 (JCT), KGBAS^{L/R}...22-35
KIGBA^{L/R}...22 (Internal)

Applicable inserts

Molded chipbreaker

Description	Dimension (mm)			MEGACOAT NANO EX		MEGACOAT NANO		Cermet		Applicable toolholders
	CW	CDX	RE	PR2015	PR2025	PR1215	PR1625	TN620		
	Edge width (W)	Available grooving depth	Corner-R							
GBA43 ^{R/L}	140-010GM	1.40	3.5	0.1	●	●	●	●	●	2
	150-020GM	1.50		0.2	●	●	●	●	●	
	175-020GM	1.75			●	●	●	●	●	
	185-020GM	1.85			●	●	●	●	●	
	200-020GM	2.00			●	●	●	●	●	
	230-020GM	2.30			●	●	●	●	●	
	250-030GM	2.50	5.0		0.3	●	●	●	●	●
	265-030GM	2.65		●		●	●	●	●	
	300-030GM	3.00		●		●	●	●	●	
	330-030GM	3.30		●		●	●	●	●	
	350-030GM	3.50		●		●	●	●	●	
	400-040GM	4.00		0.4		●	●	●	●	●

Edge width tolerance : ±0.025

● : Available

Full-R

Description	Dimension (mm)			MEGACOAT NANO EX		MEGACOAT NANO		Cermet		Applicable toolholders
	CW	CDX	RE	PR2015	PR2025	PR1215	PR1625	PV7040	TN620	
	Edge width	Available grooving	Corner-R							
GBA32R	200-100R	2.00	2.5	1.00	R	R	R	R		1
	300-150R	3.00		1.50	R	R	R	R		
GBA43 ^{R/L}	100-050R	1.00	2.0	0.50	●	●	●	●		2
	150-075R	1.50		3.5	0.75	●	●	●	●	
	200-100R	2.00	4.0		1.00	●	●	●	●	
	250-125R	2.50		5.0	1.25	●	●	●	●	R
	300-150R	3.00	4.00		1.50	●	●	●	●	
	400-200R	4.00		2.00	●	●	●	●		
GBA43 ^{R/L}	100-050RF	1.00	2.0	0.50					●	2
	150-075RF	1.50		3.5	0.75					
	200-100RF	2.00	4.0		1.00					●
	250-125RF	2.50		5.0	1.25					●
	300-150RF	3.00	1.50							●
400-200RF	4.00	2.00						R	5	

GBA43 ^{R/L} ... RF : Sharp edge type
Edge width tolerance : ±0.025

● : Available R : R-hand only in stock

CBN / PCD

Description	Dimension (mm)			CBN		PCD		Applicable toolholders
	CW	CDX	RE	KBNS10	KBNS25	KPD001	KPD010	
	Edge width (W)	Available grooving depth	Corner-R					
GBA32R	125-010	1.25	2.0	0.1		R	R	1
	150-010	1.50				R	R	
	200-010	2.00		0.1		R	R	
GBA43 ^{R/L}	125-010	1.25	2.0	0.1			●	2
	125-020			0.2	R	●		
	150-010	1.50	3.5	0.1		●	●	
	150-020			0.2	●	●		
	200-010	2.00	0.1			●	●	
	200-020			0.2	●	●		
250-010	2.50	4.0	0.1		●	●	4	
250-020			0.2	R	●			
300-010	3.00	0.1			●	R		
300-020			0.2	R	●			

Edge width tolerance : ±0.03

● : Available R : R-hand only in stock

Insert design

Shape (Right-hand)	Type	IC	S	D1
	GBA32...	9.525	3.18	4.4
	GBA43...	12.70	4.76	5.5

CDX shows available grooving depth.

Applicable toolholder description

- 1 : KGBA ^{R/L}...16 (JCT), KGBAS ^{L/R}...16
KIGBA ^{L/R}...16 (Internal)
- 2 : KGBA ^{R/L}...22-15 (JCT), KGBAS ^{L/R}...22-15
KIGBA ^{L/R}...22 (Internal)
- 3 : KGBA ^{R/L}...22-25T5/ 22-25JCT
KGBAS ^{L/R}...22-25T5, KIGBA ^{L/R}...22 (Internal)
- 4 : KGBA ^{R/L}...22-25(T5)/ 22-25JCT
KGBAS ^{L/R}...22-25(T5), KIGBA ^{L/R}...22 (Internal)
- 5 : KGBA ^{R/L}...22-35 (JCT), KGBAS ^{L/R}...22-35
KIGBA ^{L/R}...22 (Internal)

Classification of usage

- : Light Interruption /1st Choice
- : Continuous /1st Choice
- : Light Interruption /2nd Choice
- : Continuous /2nd Choice

KGBA-JCT (External grooving / Coolant-through holder)

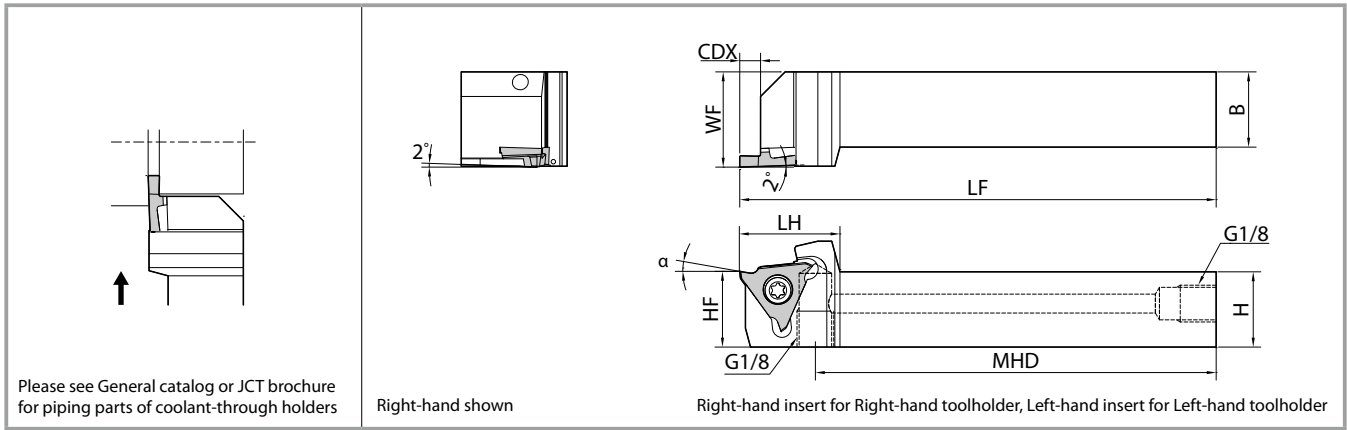

Toolholder dimensions

Description	Availability		Dimension (mm)									Spare parts				Applicable inserts	
	R	L	CDX	H	B	LH	MHD	HF	LF	WF	Plug	Screw	Wrench				
KGBA R/L	2020K-16JCT	●	●	2.5	20	20	24.0	107.5	20	125	25	HSG1/8X8.0	SB-4085TR	FT-15	-	GBA32 R/L type	
	2525K-16JCT	●	●		25	25			25								30
	2020K22-15JCT	●	●	4	20	20	26.5	105	20	25	25		SB-5085TR	-	LTW-20	GBA43 R/L type	
	2525K22-15JCT	●	●		25	25			25								30
	2020K22-25JCT	●	●	5.5	20	20	26.5	105	20	25	25		SB-5085TR	-	LTW-20		GBA43 R/L type
	2525K22-25JCT	●	●		25	25			25								
	2020K22-35JCT	●	●	5.5	20	20	26.5	105	20	25	25		SB-5085TR	-	LTW-20		GBA43 R/L type
	2525K22-35JCT	●	●		25	25			25								

CDX shows the distance from the toolholder to the cutting edge. Available groove depth : "CDX" of insert.

● : Available

KGBA-JCT toolholder is screw clamp type.

Please see General catalog or JCT brochure for piping parts and connection method



Rake angle (α) after installment of GBA insert (External grooving)

GBA32 R/L○○○ - ○○○		GBA43 R/L○○○ - ○○○		GBA43 R/L○○○ - ○○○R (Full-R)		
α	Insert grades	α	Insert grades	α	Insert grades	Full-R description
10°	TN620,TN90,PV7040 PR2015,PR2025,PR1215,PR1625 KPD001,KPD010	0°	KBN510, KBN525	10°	TN620,TN90,PV7040 PR2015,PR2025,PR1215,PR1625	050R ~ 150R
		10°	TN620,TC40N,TN90,PV7040 PR2015,PR2025,PR1215,PR1625 KPD001, KPD010		TN620,TN90,PV7040 PR2015,PR2025,PR1215,PR1625	200R
20°	KW10	20°	KW10	14°	KW10	050R ~ 200R

Rake angle (α) after installment of GBA-GM insert (External grooving)

α	Insert description	α	Insert description	α	Insert description
10°	GBA43 R/L150-020GM	15°	GBA43 R/L175-020GM } GBA43 R/L265-030GM	12°	GBA43 R/L300-030GM } GBA43 R/L400-040GM

α indicates the rake angle at the center of the edge width, after installing insert.

KIGBA (Internal grooving)

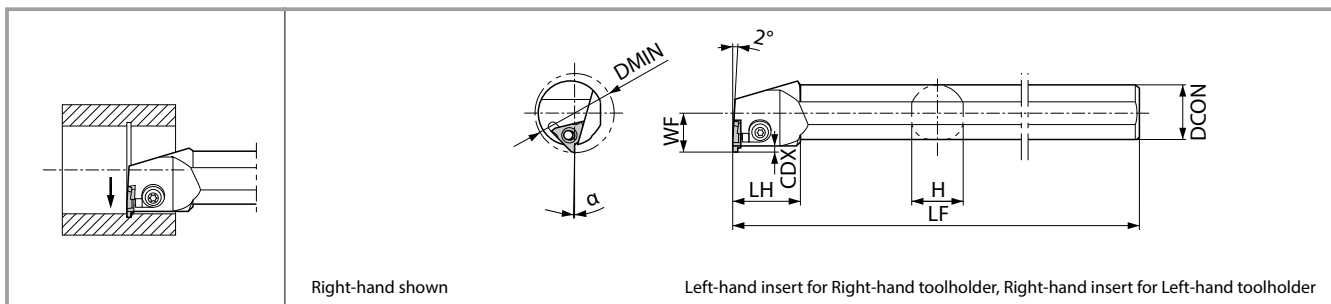

Toolholder dimensions

Description	Availability		Min. bore diameter	Dimension (mm)						Spare parts		Applicable inserts
	R	L		DMIN	DCON	CDX	H	LF	LH	F	Clamp set	
KIGBA ^{R/L} 3525-16	●	●	35	25	2.8	23	220	30	17.5	LGBA-16 ^{L/R} S	FT-15	GBA32 ^{L/R} type
	●	●	40	32	3.0	30	250	30	23.0	LGBA-22 ^{L/R} S	FT-15	GBA43 ^{L/R} type

CDX shows the distance from the toolholder to the cutting edge.
 Available Grooving Depth depends on the insert.
 KIGBA ^{R/L} 3525-16 : CDX of the applicable insert (GBA32)
 4032-22 : CDX of the applicable insert (GBA43)
 (1) 2.0 mm (CDX < 3.0 mm)
 (2) 3.0 mm (CDX ≥ 3.0 mm)

● : Available

Clamp set : LGBA-00LS for Right-hand toolholder, and LGBA-00RS for Left-hand toolholder.

Rake angle (α) after installment of GBA insert (Internal grooving)

GBA32 ^{R/L} 0000 - 0000		GBA43 ^{R/L} 0000 - 0000		GBA43 ^{R/L} 0000 - 0000R (Full-R)		
α	Insert grades	α	Insert grades	α	Insert grades	Full-R description
+1°	TN620, TN90, PV7040 PR2015, PR2025, PR1215, PR1625 KPD001, KPD010	-9°	KBN510, KBN525	+1°	TN620, TN90, PV7040 PR2015, PR2025, PR1215, PR1625	050R ~ 150R
		+1°	TN620, TC40N, TN90, PV7040 PR2015, PR2025, PR1215, PR1625 KPD001, KPD010			200R
+11°	KW10	+11°	KW10	+5°	TN620, TN90, PV7040 PR2015, PR2025, PR1215, PR1625	050R ~ 200R

Rake angle (α) after installment of GBA-GM insert (Internal grooving)

α	Insert description
+1°	GBA43 ^{R/L} 150-020GM
+6°	GBA43 ^{R/L} 175-020GM
	GBA43 ^{R/L} 265-030GM
+3°	GBA43 ^{R/L} 300-030GM
	GBA43 ^{R/L} 400-040GM

α indicates the rake angle at the center of the edge width, after installing insert.

Recommended cutting conditions ★1st recommendation ☆2nd recommendation

GBA Inserts (Ground chipbreaker)

(Wet)

Workpiece	Recommended insert grades (Vc : m/min)											(1) f for grooving (mm/rev) (2) f for turning (mm/rev) (3) ap for turning (mm)					
	MEGACOAT NANO EX		MEGA	MEGA NANO	MC	Cermet			Carbide	CBN		PCD	GBA○○ ^{R/L} 033 – 125-...	GBA○○ ^{R/L} 125 – 225-...	GBA○○ ^{R/L} 230 – 325-...	GBA○○ ^{R/L} 330 – 350-...	GBA○○ ^{R/L} 400 – 480-...
	PR2015	PR2025	PR1215	PR1625	PV7040	TN620	TC40N	TN90	KW10	KBN510 KBN525	KPD001 (KPD010)						
Carbon steel	★ 80 – 200	★ 80 – 180	☆ 80 – 200	☆ 80 – 180	☆ 150 – 240	★ 80 – 220	☆ 150 – 220	☆ 150 – 220	-	-	-	(1)0.03 – 0.08 (2)Not recom. (3)Not recom.	(1)0.04 – 0.09 (2)0.04 – 0.09 (3)Max. 0.3	(1)0.05 – 0.1 (2)0.05 – 0.1 (3)Max. 0.5	(1)0.05 – 0.12 (2)0.05 – 0.1 (3)Max. 0.5	(1)0.05 – 0.12 (2)0.05 – 0.1 (3)Max. 0.8	
Alloy steel	★ 80 – 180	☆ 80 – 160	☆ 80 – 180	☆ 80 – 160	☆ 130 – 220	★ 80 – 200	☆ 130 – 200	☆ 130 – 200	-	-	-	(1)0.03 – 0.07 (2)Not recom. (3)Not recom.	(1)0.04 – 0.08 (2)0.04 – 0.08 (3)Max. 0.3	(1)0.05 – 0.09 (2)0.05 – 0.09 (3)Max. 0.5	(1)0.05 – 0.1 (2)0.05 – 0.1 (3)Max. 0.5	(1)0.05 – 0.1 (2)0.05 – 0.1 (3)Max. 0.8	
Stainless steel	☆ 60 – 150	★ 60 – 130	☆ 60 – 150	☆ 60 – 130	-	-	-	☆ 70 – 150	-	-	-	(1)0.03 – 0.07 (2)Not recom. (3)Not recom.	(1)0.04 – 0.08 (2)0.04 – 0.08 (3)Max. 0.3	(1)0.05 – 0.09 (2)0.05 – 0.09 (3)Max. 0.5	(1)0.05 – 0.1 (2)0.05 – 0.1 (3)Max. 0.5	(1)0.05 – 0.1 (2)0.05 – 0.1 (3)Max. 0.8	
Cast iron	★ 80 – 180	-	-	-	-	-	-	-	☆ 60 – 120	★ 150 – 400	-	(1)0.03 – 0.08 (2)Not recom. (3)Not recom.	(1)0.04 – 0.09 (2)0.04 – 0.09 (3)Max. 0.3	(1)0.05 – 0.1 (2)0.05 – 0.1 (3)Max. 0.5	(1)0.05 – 0.12 (2)0.05 – 0.1 (3)Max. 0.5	(1)0.05 – 0.12 (2)0.05 – 0.1 (3)Max. 0.8	
Aluminum	-	-	-	-	-	-	-	-	★ 150 – 400	-	★ 150 – 2,000	(1)0.05 – 0.12 (2)Not recom. (3)Not recom.	(1)0.05 – 0.15 (2)0.05 – 0.15 (3)Max. 0.5	(1)0.05 – 0.15 (2)0.05 – 0.15 (3)Max. 0.8	(1)0.08 – 0.15 (2)0.08 – 0.15 (3)Max. 0.8	(1)0.08 – 0.15 (2)0.08 – 0.15 (3)Max. 0.8	
Brass	-	-	-	-	-	-	-	-	★ 150 – 300	-	★ 200 – 800	(1)0.05 – 0.12 (2)Not recom. (3)Not recom.	(1)0.05 – 0.15 (2)0.05 – 0.15 (3)Max. 0.5	(1)0.05 – 0.15 (2)0.05 – 0.15 (3)Max. 0.8	(1)0.08 – 0.15 (2)0.08 – 0.15 (3)Max. 0.8	(1)0.08 – 0.15 (2)0.08 – 0.15 (3)Max. 0.8	
Hardened material	-	-	-	-	-	-	-	-	-	★ 80 – 120	-	-	(1)0.02 – 0.05 (2)Not recom. (3)Not recom.	(1)0.03 – 0.07 (2)0.01 – 0.04 (3)Max. 0.1	-	-	

Above cutting condition is for external grooving. Set both cutting speed and feed 10% lower for internal grooving.
MEGA indicates MEGACOAT, and MEGANANO indicates MEGACOAT NANO.
MC indicates MEGACOAT Cermet.

GBA inserts (GM chipbreaker)

(Wet)

Workpiece	Recommended insert grades (Vc : m/min)					(1) f for grooving (mm/rev) (2) f for turning (mm/rev) (3) ap for turning (mm)				
	MEGACOAT NANO EX		MEGACOAT	MEGACOAT NANO	Cermet	GBA43 ^{R/L} 140-010GM	GBA43 ^{R/L} 150-020GM	GBA43 ^{R/L} 175-020GM – 230-020GM	GBA43 ^{R/L} 250-030GM – 350-030GM	GBA43 ^{R/L} 400-040GM
	PR2015	PR2025	PR1215	PR1625	TN620					
Carbon steel (SxxC etc)	★ 80 – 220	★ 80 – 220	☆ 80 – 220	☆ 80 – 220	★ 80 – 240	(1)0.03 – 0.1 (2)0.03 – 0.08 (3)Max. 0.2	(1)0.03 – 0.12 (2)0.03 – 0.08 (3)Max. 0.3	(1)0.03 – 0.12 (2)0.03 – 0.09 (3)Max. 0.3	(1)0.04 – 0.15 (2)0.05 – 0.1 (3)Max. 0.5	(1)0.05 – 0.15 (2)0.05 – 0.1 (3)Max. 0.8
Alloy steel (SCM etc)	★ 80 – 200	★ 80 – 200	☆ 80 – 200	☆ 80 – 200	★ 80 – 220	(1)0.03 – 0.1 (2)0.03 – 0.08 (3)Max. 0.2	(1)0.03 – 0.12 (2)0.03 – 0.08 (3)Max. 0.3	(1)0.03 – 0.12 (2)0.03 – 0.09 (3)Max. 0.3	(1)0.04 – 0.15 (2)0.05 – 0.1 (3)Max. 0.5	(1)0.05 – 0.15 (2)0.05 – 0.1 (3)Max. 0.8
Stainless steel (SUS304 etc)	☆ 60 – 150	★ 60 – 150	☆ 60 – 150	☆ 60 – 150	-	(1)0.03 – 0.1 (2)0.03 – 0.08 (3)Max. 0.2	(1)0.03 – 0.1 (2)0.03 – 0.08 (3)Max. 0.3	(1)0.03 – 0.1 (2)0.03 – 0.09 (3)Max. 0.3	(1)0.04 – 0.12 (2)0.05 – 0.1 (3)Max. 0.5	(1)0.04 – 0.12 (2)0.05 – 0.1 (3)Max. 0.8
Cast iron (FC/FCD etc)	★ 80 – 200	-	-	-	-	(1)0.03 – 0.1 (2)0.03 – 0.08 (3)Max. 0.2	(1)0.03 – 0.12 (2)0.03 – 0.08 (3)Max. 0.3	(1)0.03 – 0.12 (2)0.03 – 0.09 (3)Max. 0.3	(1)0.04 – 0.15 (2)0.05 – 0.1 (3)Max. 0.5	(1)0.05 – 0.15 (2)0.05 – 0.1 (3)Max. 0.8

Above cutting condition is for external grooving. Set both cutting speed and feed 20% lower for internal grooving.